

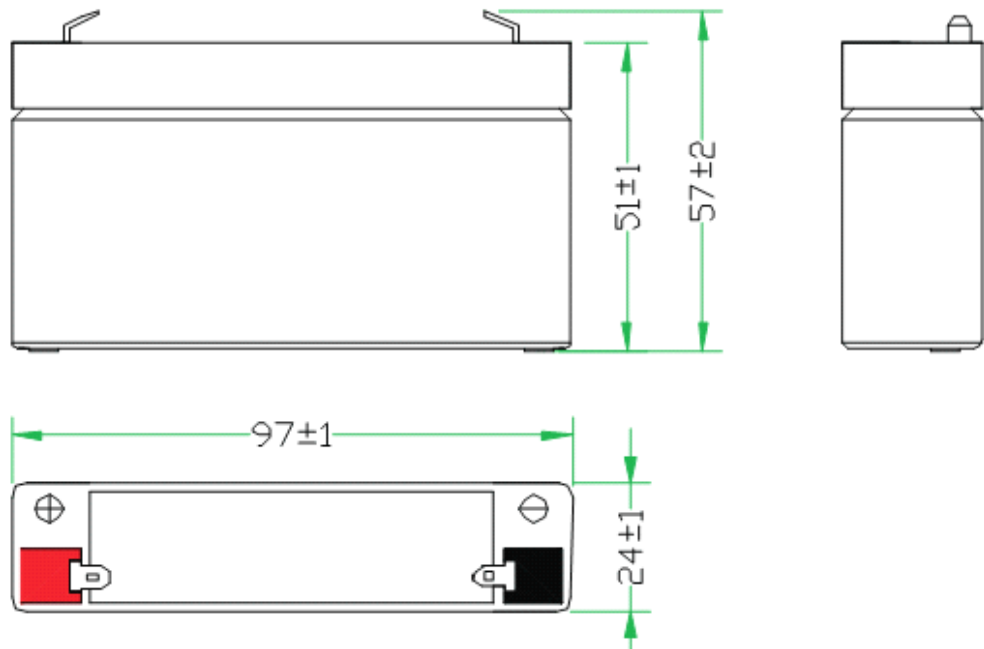

6V1.3AH



- Outer dimensions(mm)



Specifications

Nominal Voltage		6V	Rated Capacity (20 hour rate)	1.3AH
Dimensions ± 1mm	Length	97mm 3.82 inches	Weight	Approx: 260g
	Width	24mm 0.95 inches	Standard	170#
	Height	51mm 2.01 inches	Terminal	
	Total Height (With Terminals)	57mm 2.24 inches	Optional Terminal	N/A

F1 Terminal (Brass Coated with Silver)

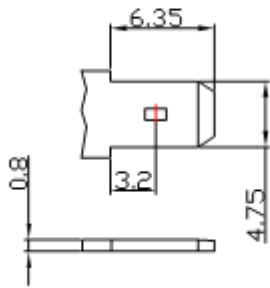

Photo

• Discharge Characteristics (25°C/77°F)

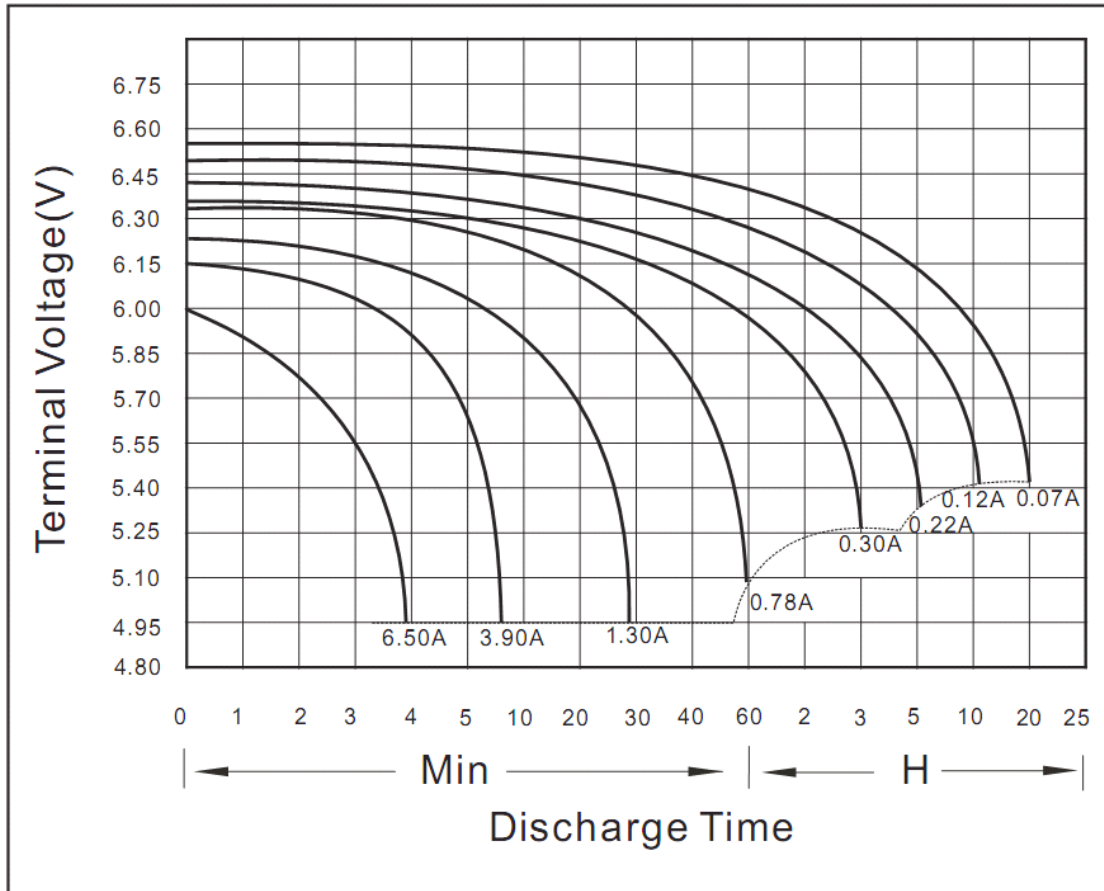

Electrical Specifications

Capacity 77°F(25°C)	20 hour rate(65mA)	1.3 AH	Internal Resistance	65mΩ
	10 hour rate(110mA)	1.1AH		
	5 hour rate(200mA)	1.0AH	Full charged battery 77°F (25°C)	
	1 hour rate(700mA)	0.7AH		
Capacity Affected by Temperature (20 hour rate)	104°F (40°C)	102%	Self- discharge 77°F(25°C)	Capacity after 1 month storage 90%
	77°F (25°C)	100%		Capacity after 3 month storage 75%
	32°F (0°C)	80%		Capacity after 6 month storage 65%
	5°F (-15°C)	50%		Capacity after 12 month storage 55%
Charge Constant Voltage	Cycle use:Initial Charging Current less than 0.39A;Voltage 7.20~7.50V 77°F(25°C) Standby use:Voltage 6.75~6.90V 77°F(25°C)			

• Discharge Characteristics(0°C/32°F–40°C/104°F)

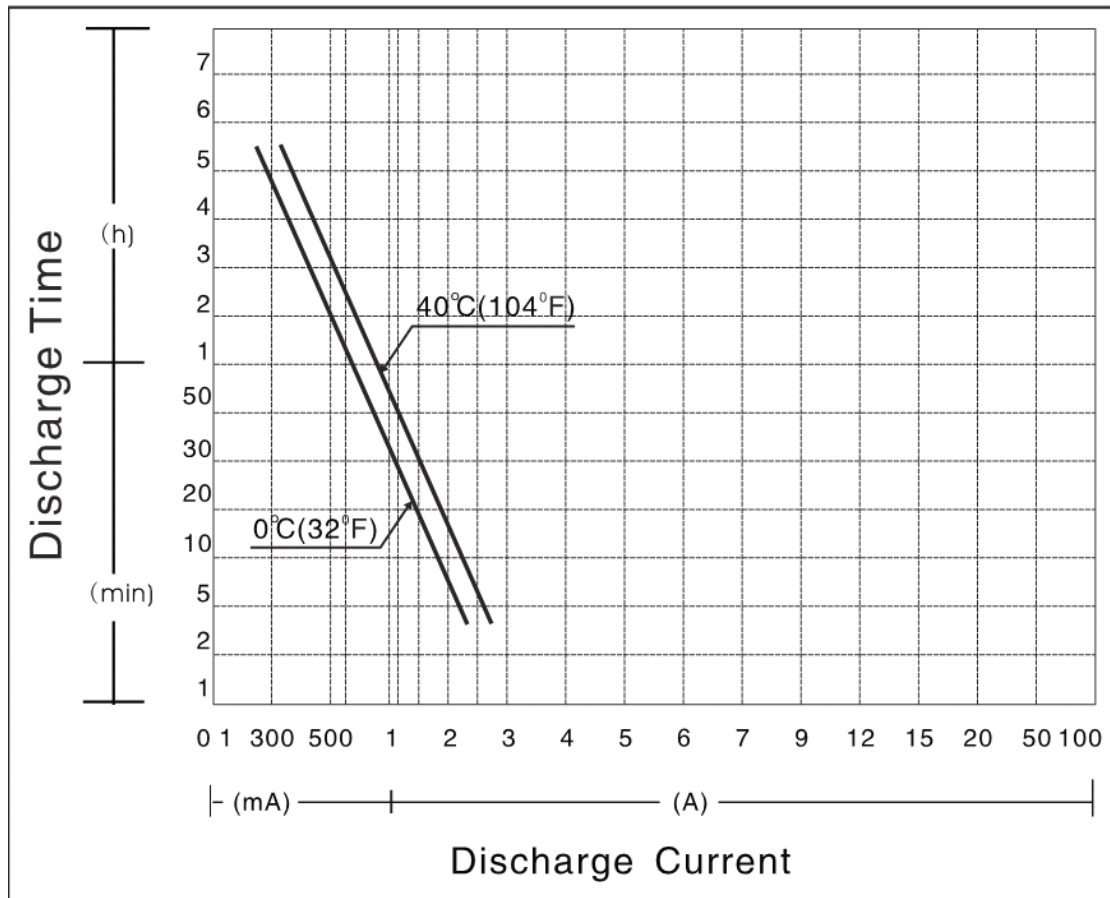

Maintenance and Attention Matters:

1. Battery is not allowed close to Tepid source or basked under the sun for a long time.

2. No charge in the obturate container

3. No short circuit. Battery should be stored full of electronic when not in need, and the battery should be charged every three months in order to avoid the irreversible sulphation. When battery case bursts or electrolyte leaks, battery should be changed lest the acid

corrosion.

4. No battery in environment with the acid gas.

5. When battery is used as the backup battery, be careful and check it at regular time to avoid the damage battery. Especially the battery beyond one year should be checked in time, and change the less capacity and scrapped battery. (some batteries maybe have voltage but no current; some batteries maybe have current but no voltage; some maybe have both but less capacity: all these conditions cannot meet the work, reach the power-on time. Do not for the small battery, cause the huge losses)

6. Forbidden battery in the fire, otherwise it will cause an explosion.

7. When battery cracks or electrolyte leaks, please use cotton cloth clear it. When skin contacts to the liquid, please wash with fresh water immediately. See doctor if serious.

8. No wash on the surface of the battery with the organic solution.

康利达国际控股集团有限公司 KANGLIDA INTERNATIONAL HOLDING GROUP CO., LTD
郑州康利达电子电源有限公司 Zhengzhou Kanglida electronic power Co., LTD
<http://www.cnbattery.cn> <http://www.klddzdy.com> Tel:86-371-6876444/55628530-816
Fax:86-371-68786444